

IntelliCon®-PTAC

PACKAGED TERMINAL AIR CONDITIONING UNIT ENERGY ECONOMIZER

Description

The *IntelliCon®-PTAC* is a patented microprocessor-based energy-saving device for Packed Terminal Air Conditioning units. The *IntelliCon®* reduces electric consumption and lowers compressor run-time by actively managing the compressor cycling pattern, in conjunction with the existing compressor controls. Note that the *IntelliCon®* can not cause the compressor to run when the controls are not calling for cooling. The *IntelliCon®-PTAC* enhances compressor protection by eliminating compressor short-cycling. This unit is compatible with Intellidyne's Remote Display Unit (model RDU). In addition to Status, the RDU will also indicate total compressor run-time and economizer time.

Electric Ratings

Power Input: 24,115,220 VAC ± 10%, 5 Watts Max., 50/60Hz
Control Circuit Input: 24,115,220 VAC ± 10%, 0.1A Max. Burden
Relay Contact: Form B, 10A @ 220 VAC

Environmental Conditions

Indoor Use
Maximum Altitude (2000M)
Rated Ambient Temperature 32 - 120°F. (0 - 49°C.)
Maximum Rh 90% non-condensing
Mains Supply Voltage Fluctuations ± 10%
Transient Overvoltage Category (III)
Pollution Degree (2)

Operation

After installation, setting the slide switch on the top of the unit to the 'ON' position activates the device. The lights on the front panel indicate the state of operation of the device and will sequence as the device goes through its operating cycle. Each light indicates one of the possible modes of operation, which are:

STANDBY MODE: The refrigeration unit's control system has shut off the compressor after cooling the space to the desired temperature. The *IntelliCon®-PTAC* is waiting for the next call for the compressor to start. This occurs for a period of time after the compressor has shut down.

ECONOMIZING: The refrigeration unit's compressor control has requested the compressor to start but the *IntelliCon®-PTAC* has intervened to delay the start based on information it has gathered from the previous run cycle.

COMPRESSOR ON: The compressor is enabled.

ANTI-SHORT-CYCLE: This is an added compressor protection feature of the device, which ensures at least a 120-second delay between compressor starts. This light will illuminate whenever the compressor has been turned off and will remain on for the 120-second protection period. The compressor can't be enabled while this light is lit.

During normal operation, the top three lights will cycle from one state to the next and the anti-short-cycle light will come on for thirty-seconds after the compressor is stopped.

Installation

The *IntelliCon®-PTAC* is electrically installed in series with the refrigeration unit's compressor control as shown in the wiring diagrams on the reverse side. Check and determine the voltages of the compressor control circuit and power circuit prior to installation. **FOR SAFETY, POWER TO THE UNIT MUST BE DISCONNECTED DURING INSTALLATION.**

Positioning

The unit must be protected from the elements and may be mounted on the equipment either vertically or horizontally. The unit should be mounted in the electric enclosure using #6 or #8 hardware in the corners of the control.

Wiring

All wiring and connections must comply with Local and National Electrical Codes. The unit should be wired as shown in the wiring diagrams on the reverse side. It is important to read all of the instructions carefully. Ensure that **POWER TO THE UNIT IS OFF DURING INSTALLATION.**

Checkout

Recheck wiring one last time. Then restore power to the AC unit. First, as part of the system check, all four (4) lights on the *IntelliCon®-PTAC* will be briefly lit and then go out. Next the revision level of the software will be output via a sequence of flashing of the LEDs. Next, either the 'STANDBY MODE', or the 'ECONOMIZING' light will activate depending upon the operating state of the refrigeration unit controls. The 'ANTI-SHORT-CYCLE' light will come on and remain on for 120-seconds. This is normal during power-up. After the 120-second interval, the 'ANTI-SHORT-CYCLE' light will go out. Next, if the 'ECONOMIZER' light is lit, after a short delay the 'COMPRESSOR ON' light will light and the compressor should start. If this happens, the installation is complete.

If the *IntelliCon®-PTAC* remains in the 'STANDBY MODE' after the 'ANTI-SHORT-CYCLE' light goes out, it will be necessary to simulate a cooling call to verify proper operation. Note the control thermostat and force a compressor call by temporarily resetting the control. Verify that the *IntelliCon®-PTAC* has changed modes to either 'ECONOMIZING' or 'COMPRESSOR ON'. This indicates the unit is operating normally. **Make sure to return the thermostat to its' previous setting.** If the *IntelliCon®-PTAC* does not come out of 'STANDBY MODE' when the unit's control is calling for the compressor to run, the unit is probably miswired; see the WIRING NOTE below.

Service and Troubleshooting

After Installation and Checkout, the *IntelliCon®-PTAC* requires no maintenance and will provide years of trouble free operation.

Timed OFF Cycle jumper settings

This control has the capability to force the compressor off for a pre-determined amount of time, if the compressor is running continuously for a pre-determined time. This allows the control to provide additional savings on systems that are marginally sized, or have special requirements. This feature has eight settings that are adjustable via jumper setting on the control's circuit board. To understand, the cycle off parameter 1,15 means that the compressor will be cycled 'off', once per hour (of continuous running) for 15% of the time (Default setting). So, if the compressor was running continuously for 51 minutes [60 minutes minus 15% of 60 minutes = 51 minutes] of the hour, it will be forced 'off' for 9 minutes (15% of 60 minutes = 9 minutes). 2,15 would mean the compressor would be cycled 'off' twice per hour for 15% of the time. That equates to the compressor being forced 'off' every 25.5 minutes for 4.5 minutes. Remember, this only occurs if the compressor is running continuously for the prescribed amount of time.

Please Note: If improperly set, this feature may cause temperature fluctuations beyond the required tolerance and should not be adjusted without proper understanding.

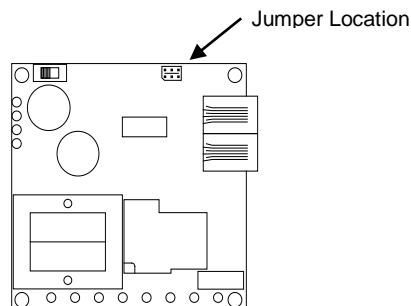
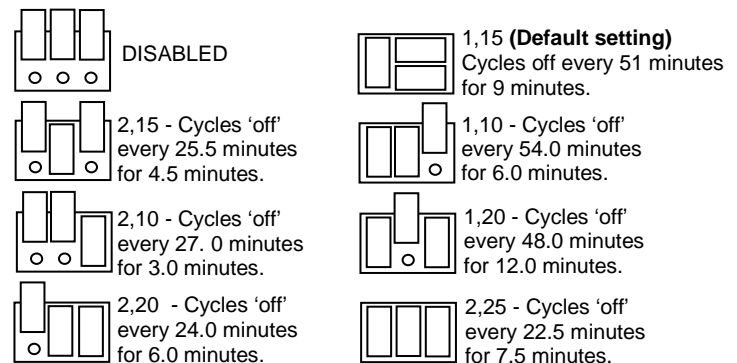
**IMPORTANT - READ CAREFULLY**

1. Failure to follow these instructions may result in damage to the system or cause a hazardous condition.
2. Installer must be experienced, qualified, and in certain locations, licensed to work on the system that this control is being installed on.
3. After installation is complete, follow the check-out procedure as provided in these instructions to confirm proper system operation.
4. Intellidyne is not responsible for improper installation or any damages that may result from improper installation.
5. Actual wiring may differ from that shown in the diagrams.
6. Equipment may have controls not shown.
7. Because the *IntelliCon* can operate with different voltages for the power and control circuits, it has separate common wires for these circuits. It is necessary that those wires are connected to the proper commons or the unit will not function properly. See the wiring diagrams on the reverse side of this sheet for details.

IMPROPER VOLTAGE SELECTION MAY DAMAGE THE UNIT AND VOID THE WARRANTY.

IntelliCon®-PTAC

PACKAGED TERMINAL AIR CONDITIONING UNIT ENERGY ECONOMIZER

Typical Control Wiring

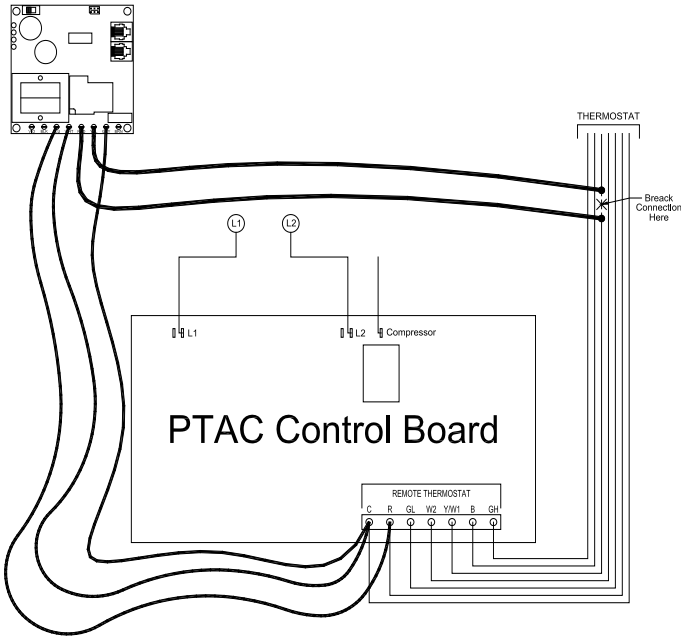

24 VAC Power / 24 VAC Compressor Control

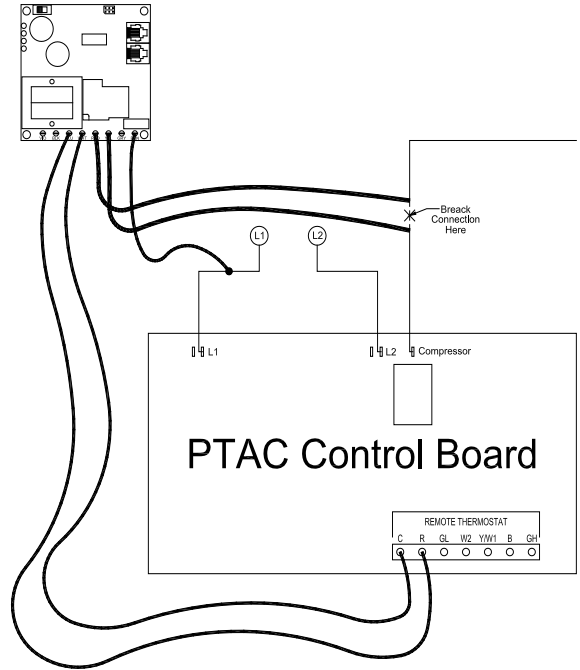

24 VAC Power / 208-220 VAC Compressor Control

IMPORTANT NOTE

There are eight (8) fully insulated crimp-on quick connection terminals provided. The pink colored ones will handle #18 - #16 gauge wire. The Blue will handle #16 - #14 gauge wire. The Blue terminals should be used on the RED and YEL terminals since they require a heavier gauge wire.

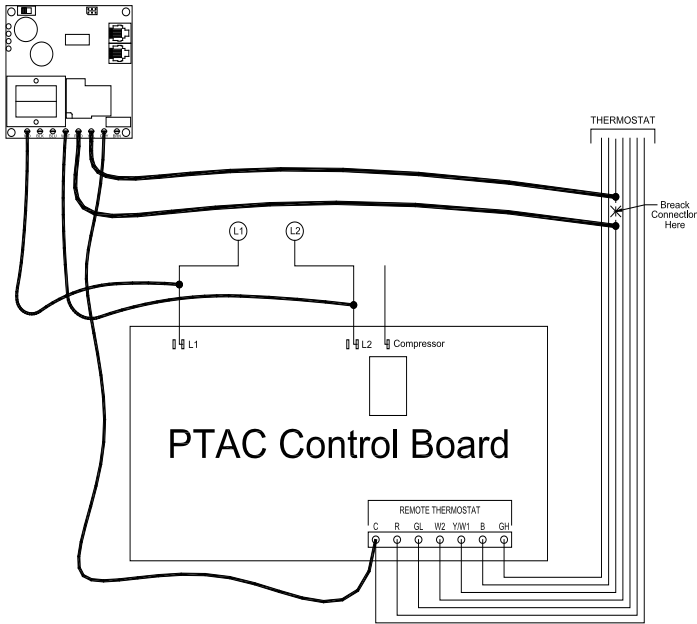

208-220 VAC Power / 24 VAC Compressor Control

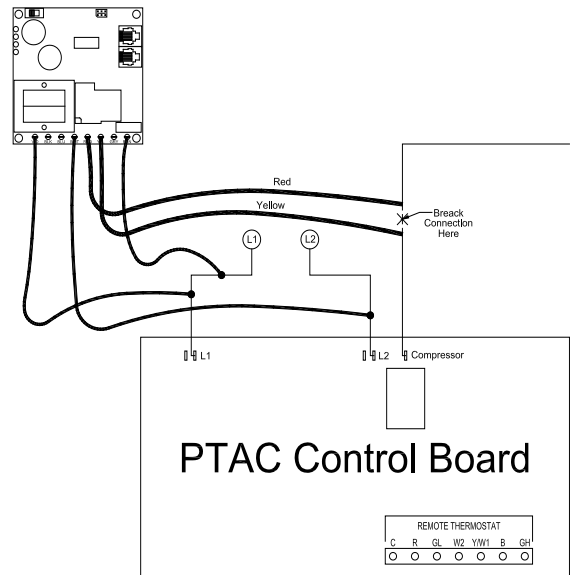

208-220 VAC Power / 208-220 VAC Compressor Control