

**IntelliCon®-RU**

## COMMERCIAL REFRIGERATION ENERGY ECONOMIZER

**Description**

The *IntelliCon®-RU* is a patented microprocessor-based energy-saving device for commercial refrigeration systems. The *IntelliCon®* reduces electric consumption and lowers compressor run-time by actively managing the compressor cycling pattern, in conjunction with the existing compressor controls. Note that the *IntelliCon®* can not cause the compressor to run when the controls are not calling for cooling. The *IntelliCon®-RU* enhances compressor protection by eliminating compressor short-cycling. This unit is compatible with Intellidyne's Remote Display Unit (model RDU). In addition to Status, the RDU will also indicate total compressor run-time and economizer time.

**Electric Ratings**

Power Input: 24, 115, 220 VAC ± 10%, 5 Watts Max., 50/60Hz  
Control Circuit Input: 24,115,220 VAC ± 10%, 0.1A Max. Burden  
Relay Contact: Form B, 10A @ 220 VAC

**Environmental Conditions**

Indoor Use  
Maximum Altitude (2000M)  
Rated Ambient Temperature 32 - 120°F. (0 - 49°C.)  
Maximum Rh 90% non-condensing  
Mains Supply Voltage Fluctuations ± 10%  
Transient Overvoltage Category (III)  
Pollution Degree (2)

**Operation**

After installation, setting the slide switch on the top of the unit to the 'ON' position activates the device. The lights on the front panel indicate the state of operation of the device and will sequence as the device goes through its operating cycle. Each light indicates one of the possible modes of operation, which are:

**STANDBY MODE:** The refrigeration unit's control system has shut off the compressor after cooling the space to the desired temperature. The *IntelliCon®-RU* is waiting for the next call for the compressor to start. This occurs for a period of time after the compressor has shut down.

**ECONOMIZING:** The refrigeration unit's compressor control has requested the compressor to start but the *IntelliCon®-RU* has intervened to delay the start based on information it has gathered from the previous run cycle.

**COMPRESSOR ON:** The compressor is enabled.

**ANTI-SHORT-CYCLE:** This is an added compressor protection feature of the device, which ensures at least a thirty-second delay between compressor starts. This light will illuminate whenever the compressor has been turned off and will remain on for the thirty-second protection period. The compressor can not be enabled while this light is lit.

*During normal operation, the top three lights will cycle from one state to the next and the anti-short-cycle light will come on for thirty-seconds after the compressor is stopped.*

**Installation**

The *IntelliCon®-RU* is electrically installed in series with the refrigeration unit's compressor control as shown in the wiring diagrams on the reverse side. Check and determine the voltages of the compressor control circuit and power circuit prior to installation. **FOR SAFETY, POWER TO THE UNIT MUST BE DISCONNECTED DURING INSTALLATION.**

**Positioning**

The unit must be protected from the elements and may be mounted on the equipment either vertically or horizontally. The unit should be mounted directly on the existing electric enclosure via the unit's standard ½" electrical fitting or within the enclosure using an accessory mounting bracket. For mounting in the elements, a rain-tight mounting enclosure is available.

**Wiring**

**All wiring and connections must comply with Local and National Electrical Codes. The unit should be wired as shown in the wiring diagrams on the reverse side. It is important to read all of the instructions carefully. Ensure that POWER TO**

**THE UNIT IS OFF DURING INSTALLATION and that all unused leads are individually taped/insulated.**

**Checkout**

Recheck wiring one last time. Set the *IntelliCon®-RU* slide switch to 'Off/Bypass' and restore power to the compressor. Set the slide switch to 'On'. First, as part of the system check, all four (4) lights on the *IntelliCon®-RU* will be briefly lit and then go out. Next, either the 'STANDBY MODE', or the 'ECONOMIZING' light will activate depending upon the operating state of the refrigeration unit controls. The 'ANTI-SHORT-CYCLE' light will come on and remain on for thirty-seconds. This is normal during power-up. After the thirty-second interval, the 'ANTI-SHORT-CYCLE' light will go out. Next, if the 'ECONOMIZER' light is lit, after a short delay the 'COMPRESSOR ON' light will light and the compressor should start. If this happens, the installation is complete.

If the *IntelliCon®-RU* remains in the 'STANDBY MODE' after the 'ANTI-SHORT-CYCLE' light goes out, it will be necessary to simulate a cooling call to verify proper operation. Note the control thermostat or pressuretrol setting and force a compressor call by temporarily resetting the control. Verify that the *IntelliCon®-RU* has changed modes to either 'ECONOMIZING' or 'COMPRESSOR ON'. This indicates the unit is operating normally. *Make sure to return the compressor control to its previous setting.* If the *IntelliCon®-RU* does not come out of 'STANDBY MODE' when the unit's control is calling for the compressor to run, the unit is probably miswired; see the WIRING NOTE below.

**Service and Troubleshooting**

After Installation and Checkout, the *IntelliCon®-RU* requires no maintenance and will provide years of trouble free operation.

The unit may be bypassed at any time by putting the slide switch to the 'Off/Bypass' position. In this position, the unit has no effect on the system and the compressor will function as it did prior to the *IntelliCon®-RU* installation. This allows service personnel to diagnose problems without the *IntelliCon®-RU* interfering.

**IMPORTANT - READ CAREFULLY**

1. Failure to follow these instructions may result in damage to the system or cause a hazardous condition.
2. Installer must be experienced, qualified, and in certain locations, licensed to work on the system that this control is being installed on.
3. After installation is complete, follow the check-out procedure as provided in these instructions to confirm proper system operation.
4. Intellidyne is not responsible for improper installation or any damages that may result from improper installation.
5. Actual wiring may differ from that shown in the diagrams.
6. Equipment may have controls not shown.
7. Because the *IntelliCon* can operate with different voltages for the power and control circuits, it has separate common wires for these circuits. It is necessary that these wires are connected to the proper commons or the unit will not function properly. See the wiring diagrams on the reverse side of this sheet for details.

**IMPROPER VOLTAGE SELECTION MAY DAMAGE THE UNIT AND VOID THE WARRANTY.**



**Typical 1Ø or 3Ø Pump-down Type Refrigeration Systems**

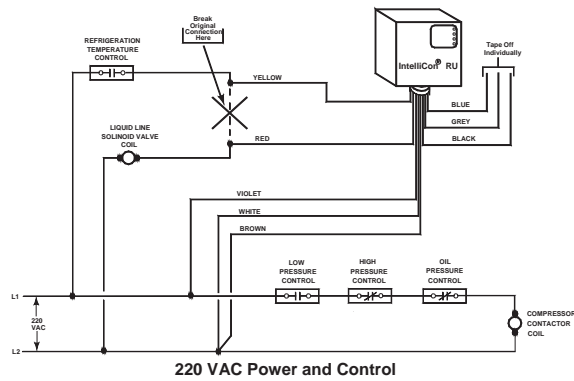
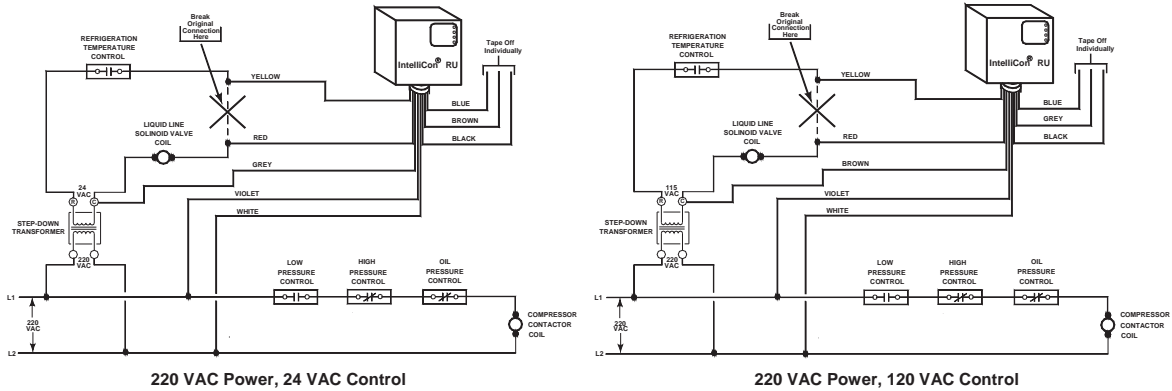

**Typical 1Ø or 3Ø Pressure Control Type Refrigeration Systems**

